

E-Series Padlock

Protected Shackle



Application

Extra high security padlock, for general use with Mul-T-Lock high security padbars.

Operation

The shackle is locked by a double ball bearing mechanism. Unlocking with 90° key rotation.

Options

Available with high (protected) or low upper body. Black electrophoretic finish. Retained shackle.

Materials

Body: Case Hardened Steel.

Shackle: Hardened Boron Alloy Steel.

Additional Features

Rotating disk or anti-drilling pins (E-8) in the cylinder provide drilling resistance. Protective shutter prevents dust contamination. Drainage holes prevent freezing.

Cylinder Mechanism

Mul-T-Lock unique high precision 10 telescopic pin tumbler system. Pick and drill resistant for high security needs.

Keys

Reversible Nickel Silver key with plastic key head and coloured insert for identification. Also available in all-Nickel Silver.

Key Security

Orders for keys marked "do not duplicate" should only be made upon presentation of a key card.

Cylinder Options

Interactive® (patented).

'3 IN 1' (Changeable combination).
Keyed different, Keyed alike, Master keyed.

Standards

Applicable "CEN", "ASTM".

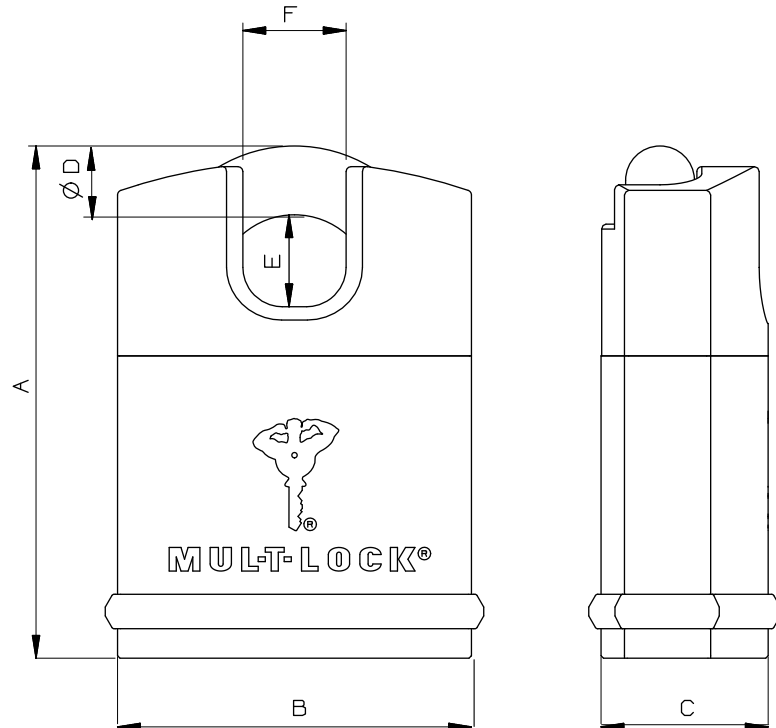

Model	Body			Shackle			Standard Grades*		Suitable Padbar	
		A	B	C	D	E	F	"CEN"		"ASTM"
E8-H	mm	84	52	33	8	15	16	4	6	PB-8
	Inch	3.228	2.047	1.229	0.314	0.551	0.629			
E11-H	mm	95	62	34	11	16	17	5	6	PB-11
	Inch	3.700	2.440	1.338	0.433	0.629	0.669			
E14-H	mm	107	72	34	14	19	21	6	6	PB-14
	Inch	4.094	2.834	1.338	0.551	0.748	0.826			
E18-H	mm	122	84	40	18	24	25	6+	6	PB-14
	Inch	4.606	3.307	1.574	0.708	0.944	0.984			

*Applicable to "ASTM", "CEN" grade standard.